

A Review on Recent Low Voltage Ride-Through Solutions of Wind Farm for Permanent Magnet Synchronous Generator

R. A. Ibrahim*, M.S. Hamad*, Y.G. Dessouky*, B.W. Williams*

* Arab Academy for Science and Technology, Alexandria, (Egypt)

** Strathclyde University, Glasgow, (United Kingdom)

Abstract-- Research of grid connecting wind turbines has gained great interest in the recent years. This led to new guidelines and regulations regarding the connection of large wind farms to the power system network. One of which is Low Voltage Ride-Through (LVRT). In this paper, a survey on recent LVRT solutions for Permanent Magnet Synchronous Generators (PMSG) is reviewed along with a brief explanation of grid codes. De-loading of a fully rated converter wind turbine, control of Blade Pitch Angle (BPA) and capacitor sizing are illustrated. The idea of an active crowbar rotor circuit and the DC bus energy storage circuit are reviewed. Detailed analysis on the research status and industrialization of high power FACTS devices for LVRT is carried out. New technologies aiming at enhance LVRT capability and steady-state performances are proposed. The survey provides possibilities for the development of further LVRT research at the wind farm level.

Index Terms— permanent magnet synchronous generator, low voltage ride through, wind energy grid connection, renewable energy

I. INTRODUCTION

The number of wind turbines connected to electricity networks in Europe is increasing rapidly. The significant increase in wind power capacity has led to concerns about power system stability as wind farms replace or are installed instead of conventional generating technologies that use fossil fuels as the primary energy source. One of these concerns is the issue of low-voltage ride-through (LVRT). Before 2003, there were no requirements from utility grids for an LVRT-performance of Wind Turbine Generators (WTG), but in that year E.ON-Netz of Germany was the first to implement this need into their grid code. Wind turbines are now expected to behave like conventional synchronous generators during voltage dips, remaining connected and supplying reactive power during and after the voltage dip has ended [1].

Grid code specifications in European countries require that wind turbines must be able to ride through grid disturbances that bring voltages down to very low levels. As an example, Figure 1 is a diagram of the LVRT requirements in some European countries. The wind farm has to remain connected to the network for grid faults that last up to 140ms and upon the restoration of voltage to 90% of nominal, a wind farm has to supply active power to at least 90% of its pre-fault value within 0.5s. For

super grid voltage dips (duration is greater than 140 ms), the wind farm has to remain connected to the system for any dip-duration on or above the heavy black line of as demonstrated in [2]. Also, wind farm must supply maximum reactive current to the grid without exceeding the transient rating of the wind plant. The wind farm has to supply active power to at least 90% of its pre-fault value within 1s of restoration of voltage to 90% of nominal. [3]

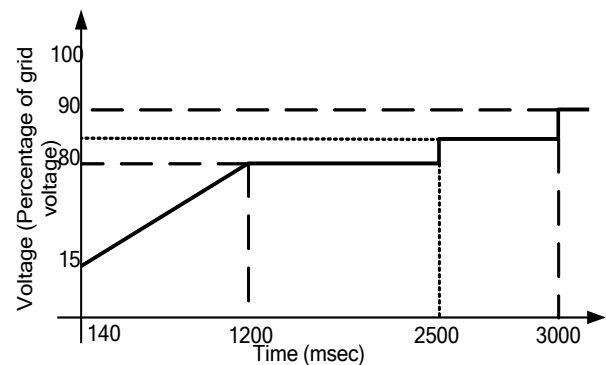

Figure 1: Fault Ride Through in some European Countries

II. PROBLEM DESCRIPTION

When a fully rated converter wind farm is connected to an AC network and a network fault occurs, the DC link voltages of the wind turbines will rise rapidly because the grid side converters of the wind turbines are prevented from transmitting all the active power coming from the generators. The power imbalance between mechanical input power of the generator and the electrical output power accelerates the generator. If this situation is allowed to continue, not only will the generator damage by over-current but also the power converters will soon be damaged as well. Consequently, a total cutout of the wind farm will soon occur. If the wind farm is connected to a weak electrical grid, fear of loss of this large Mega Watt (MW) might threaten the network stability.

Therefore, in order to maintain the wind turbines' DC link voltages below their upper limit, the excess power has to be dissipated or the generator power has to be reduced. The solutions to enhance the voltage ride through capability are usually based on the following criteria as mentioned in [4]:

- 1) Grid variable: voltage during fault, voltage overshoots at recovery, response time.

- 2) Turbine variables: rotor speed, rotor current, dc bus voltage

In the following sections, recent and commonly used techniques to overcome the low voltage ride through problem will be discussed showing merits and demerits of each technique. The methods reviewed in this paper are suitable for direct driven permanent magnet based wind generation systems.

III. METHODS FOR LVRT CAPABILITY ENHANCEMENT

A. Control of Blade Pitch Angle (BPA):

Wind turbines are categorized into four main types [5]:

- 1) Fixed-Speed Wind Turbines (FSWTs) with fixed pitch;
- 2) FSWTs with variable pitch (active stall);
- 3) Variable-Speed Wind Turbines (VSWTs) with doubly-fed induction generators (DFIGs);
- 4) VSWTs with fully-rated converters.

Therefore, pitch control is a central feature of most wind turbines. Pitch controller works in coordination with the protective relay system for wind turbine so that when grid voltage dip is detected by the fast response under voltage relay, the pitch controller is initiated. [6]

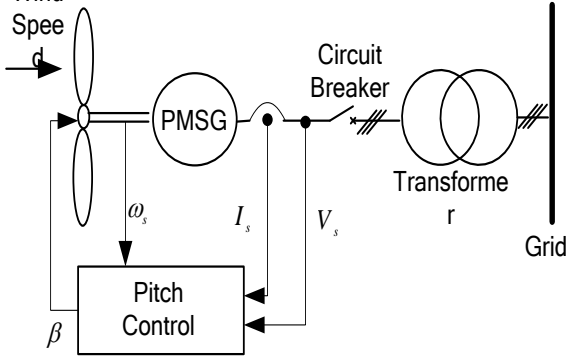

Figure 2: Control of Blade Pitch Angle

According to [7], the power absorbed by windmill from air, P_w , is given as in equation (1)

$$P_w = \frac{1}{2} \rho \pi R^2 V^3 C_p \quad (1)$$

Where ρ is air density, V is wind velocity, R is windmill blade radius, C_p is the performance coefficient which is a function of tip-speed ratio (TSR) λ and the blade pitch angle (BPA) β , ω is mechanical rotational speed of windmill. When wind velocity is invariable the power P_w is directly proportional to C_p .

$$\lambda = \frac{\omega R}{V} \quad (2)$$

$$C_p = 0.73 \left(\frac{151}{\lambda_1} - 0.58\beta - 0.02\beta^{2.14} - 13.2 \right) e^{-\frac{18.4}{\lambda_1}} \quad (3)$$

$$\lambda_1 = \frac{1}{\left(\frac{1}{\lambda - 0.02\beta} - \beta^3 + 1 \right)} \quad (4)$$

As it can be noticed from equation (1) to equation (4), the performance coefficient C_p varies as a function of both the TSR and the BPA. For every fixed BPA there is a corresponding $C_p - \lambda$ curve. On every curve there is a peak C_p value corresponding to an optimum TSR.

Maximum C_p is achieved at optimized rotational speed ω when BPA β is equal to zero [8]. As to avoid over speeding of a wind turbine in response to network voltage dips, a BPA controller is needed where the pitch controller pitches the BPA to reduce the performance coefficient of the turbine above rated rotational speed and rated power of the generator. The BPA is adjusted to reduce the wind power to keep the rotational speed from speeding up and shifting the operating away from its maximum value ($\beta = 0$) to along the vertical line. When the voltage recovers BPA is adjusted to bring the wind turbine back to the point where $\beta = 0$. There are significant response limitations when this method is applied to smaller power systems. Dynamic forces resulting from restoring power at a high rate during fault are high even though the blade pitch actuators are powerful enough to fully pitch the blades in a very small time.

B. Capacitor sizing:

Another way of dealing with the excess energy during a voltage dip is to store it in a larger capacitance as seen in equation (5):

$$\int P_c dt = \frac{1}{2} C (V^2 - V_0^2) \quad (5)$$

Where, P_c is the energy stored in the capacitor, C is the value of capacitance in Farad, V is the value of capacitor voltage at the event of voltage dip and V_0 is the capacitance voltage during normal operation (in the absence of voltage dips). Using the numerical example in [9], it is observed that the required capacitor power P_c is directly proportional to the dip voltage. Also, the required capacitor size will increase if the voltage dip duration increases, making the capacitor sizing technique an impractical solution.

C. The Active Crowbar Rotor Circuit (Braking Resistors):

A resistor is inserted in the dc circuit to dissipate the excess energy and restore the energy balance. There are two types of crowbar systems: passive and active. The latter is more popular because of the fully controllable characteristics. As seen in Figure 3, this type of crowbar consists of semiconductor switches such as GTOs or IGBTs.

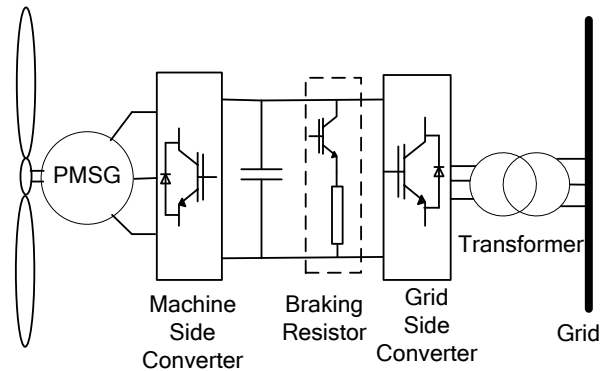

Figure 3: Braking Resistance for PMSG Based Systems

If DC link voltage exceeds its limits, the IGBTs of the grid side converter are blocked and the active crowbar is

turned on. Some hardware modification can be used to improve the fault ride through capability using the crow bar approach by using a set of resistors, series antiparallel thyristors, static series compensator (SSC), or STATCOM. However, this approach is usually more expensive. [10]. Figure 3 shows the positioning of this braking resistor RB and its controlling switch [9]. For prolonged voltage dips, switch and resistor may be problematic, hence there should be a way to reduce the required power dissipation. Decreasing the captured wind power by increasing the blade pitch angle will reduce the energy imbalance and thus the required braking resistor power will decrease. [11]

D. The DC Bus Energy Storage Circuit:

Wind energy systems have a fluctuating power output due to its nature and due to the variability of the wind speed. Integrating an appropriate energy storage system in conjunction with a wind generator removes the fluctuations and can maximize the reliability of power to the loads. For these reasons, energy storage systems (ESS) can be helpful in enhancing the LVRT capability for wind turbines. This is done by providing an alternative path for the generator currents, effectively preventing them from affecting the dc link capacitor voltage significantly as seen in Figure 4.

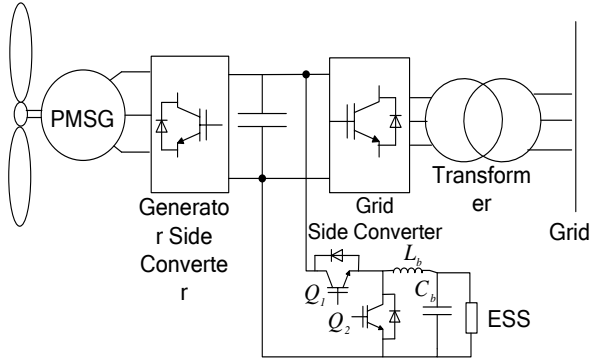

Figure 4: Energy Storage System Technique for DFIG Based Systems Batteries such as lead-acid batteries (LAB), sodium sulfur batteries and vanadium redox flow battery (VRB) are well suited for energy storage and can be used in large-scale power energy storage because of their high scalability, long life, low materials price, low maintenance requirements, large capacity, and fast response to rapid changes. In practice, LAB are more dominant in the market share but VRB have more superior characteristics. VRB have higher energy and power density, lower maintenance cost and longer life time [12-14].

By adding VRB-based ESS at DC-link bus, the energy can be stored or released to smooth the grid-injected power. In addition, when the grid voltage sags, VRB-based ESS could absorb the excessive energy from the DC-link bus to improve the LVRT capability effectively. [12] This can be achieved through proper charging and discharging of the battery and control of the ESS. It was found that this method is affected more by the fault severity than the type of fault. The method requires the dc converter and an energy storage system as well as appropriate sizing of the rotor-side converter.[4, 13]

E. De-loading of a fully rated converter wind turbine:

One way of reducing the DC link voltage is by de-loading the wind turbine. Fully rated converter wind turbines can be de-loaded in two different ways for fault ride through. As mentioned in [14], One way is to reduce the generator torques via generator side converter control and the other alternative is to block the output powers via wind turbines' grid side converter control through setting the active power current components to zero.

i- Control of Generator-side Rectifier (GSR):

In case of reducing the generator torque via the generator side converter, the generator power is rapidly reduced (de-loaded) by reducing the generator torque as soon as the DC link voltage reaches a certain threshold. The reduction in generator torque follows de-loading droop characteristics which in fact must be fast enough to de-load a large MW wind turbine in just few milliseconds. As the wind turbines' DC link voltage drops, the grid side controller reduces the wind farm grid side active power current, thus reducing the active power from the wind farm.

Electromagnetic torque T_e is managed through controlling the armature current, and thus the rotational speed of generator is controlled. Negative torque is applied to the PMSG if energy direction is defined on the basis of an electric motor.

Figure 5 shows the control block diagram of GSR.

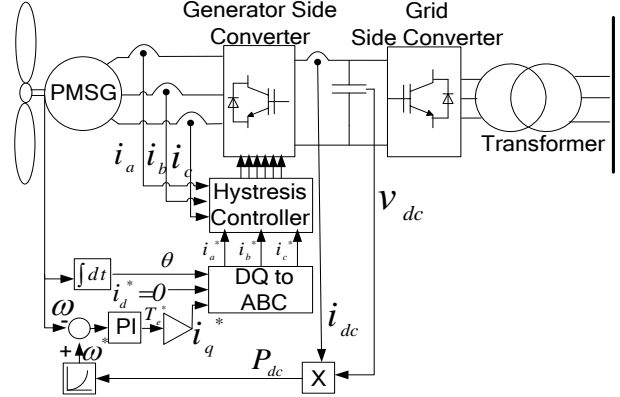

Figure 5: Control of Generator Side Converter

There are two control loops that are utilized; the inner control loop is the current loop while the outer one is the power loop. In the inner control loop, the d-axis reference current i_{dref} is set to zero and the q-axis reference current i_{qref} is obtained from the outer power loop. The cross-coupling decoupling is employed on current components of d-q axes to manage the active and reactive power of the PMSG independently. As previously stated, the maximum power at different wind velocities is almost a cubic function of generator speed as shown in equation (1). Therefore the generator speed is controlled in order to follow the power-speed characteristic. For this purpose, the power at dc-link is used to obtain reference speed by using the power-speed curve of the generator. The error of this reference speed and actual speed is then given to the proportional-integral (PI) regulator to obtain reference torque of the generator expressed as in equation (6) as mentioned in [15].

$$T_e^* = \left(k_{p\omega} - \frac{k_{f\omega}}{s} \right) (\omega_r^* - \omega_r) \quad (6)$$

Since the torque current component is the q-axis component, thus the d-axis component can be set to zero to obtain maximum torque at minimum current and therefore to minimize the resistive losses in the generator.

ii- Control of Grid-side Inverter (GSI):

In case of de-loading via wind turbine grid side controller, the wind turbines' grid side active power current is reduced to block the wind turbine output power. Reducing the power at the wind turbine grid side converter increases the wind turbine DC link voltage and in turn activates the wind turbine de-loading controller. GSI is responsible for the DC to AC conversion and regulation of the dc-link voltage so that the power balance can be maintained under both fluctuating wind and grid disturbances. Control block diagram of GSI is presented in Figure 6 where cross-coupling decoupling is employed on current components of d-q axes to manage the active and reactive power injected into power grid independently. The inner control loop is current loop which can be used in reactive power or harmonic compensation, as per the demand of non-linear load at PCC. The outer one is voltage loop to set the current reference for active power control [15].

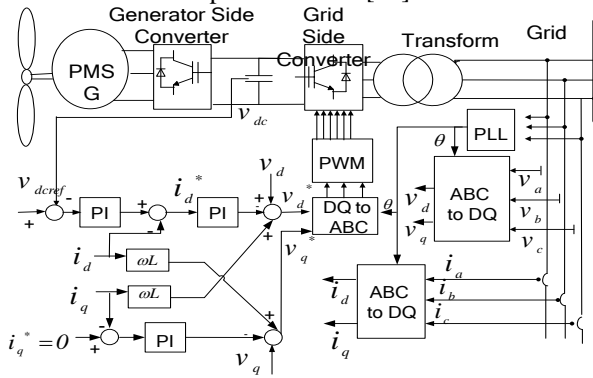

Figure 6: Control of Grid Side Converter

Controllers are often designed to operate in a specific range of operating points. When the terminal voltage drops below the nominal level, the operating point may go out of the designed range for the PI controllers, resulting in an unexpected response which could cause converter transient currents to exceed their limits. Due to its limited ability, grid side controller technique more sophisticated control techniques to enhance the low voltage ride through capability. [16].

iii- Control using Boost converter:

In this type of control the objective of the boost converter is to maintain the dc-link voltage constant as seen in Figure 7. The grid-side inverter is controlling the reactive power as usual while the generator side converter is to track the power command to capture the optimal energy from the wind [17]. The boost converter adopts double control loops. The current i_i is controlled in the inside loop, and dc-link voltage v_{dc} is controlled in the outside loop, which makes sure the dc-link voltage constant. During the period of voltage dip at the point of common coupling of wind turbine system, the active power P_{Grid} exported into the grid is reduced because of

the low grid voltage v_{abc} . In order to keep the DC link voltage constant, the boost converter will decrease the inside current i_i so as to reduce the generator output power P_{Gen} . Therefore, the uncontrollable increase of the dc-link voltage will be neglected [18].

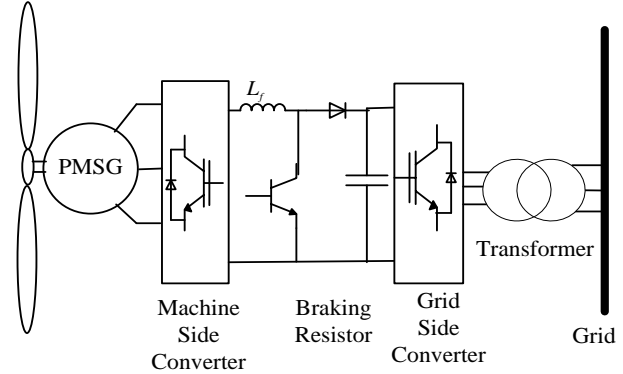

Figure 7: Boost Converter Control

F. Using FACTS and Compensation Techniques:

Several solutions have also been proposed for reactive power and voltage recovery at the point of common coupling[19]. Basically, there are two types: shunt and series FACTS. With shunt compensation, a large reactive current is injected. The size of the reactive current is decided by the difference between the wind farm consumption requirement and the amount of reactive power that can be transferred from the grid with the given voltage conditions. Series compensation is on the other hand based on increasing the reactive power transfer from the grid. By injecting a capacitive voltage, the voltage across the grid impedance will increase and increased reactive power transfer can be achieved. kVAR rating of the compensator in this case is reduced as only parts of the required reactive power will come from the compensator itself.

i- Shunt Compensation:

SVC

A Static VAR Compensators (SVC) consists of a thyristor controlled reactor, and thyristor or mechanically switched capacitors. By means of phase angle modulation switched by the thyristors, the reactor may be variably switched into the circuit and so provide a continuously variable MVAR injection (or absorption) to the electrical network. SVCs can significantly increase the LVRT capability and critical clearing time without much cost increasing. SVC is known for its voltage support of critical loads, transient stability improvement and power oscillation damping in electric power transmission systems. The connection the the SVC can be seen in Figure 8.

STATCOM

A STATCOM is a second-generation flexible ac transmission system controller based on a self-commutating solid-state voltage source inverter which converts dc voltage into a three-phase set of output voltages with desired amplitude, frequency, and phase. Its main features are higher control bandwidth and the additional capability of providing higher currents at low

voltage levels. The main advantage of the STATCOM over thyristor type SVC is that the compensating current does not depend on the voltage level of the connecting point and thus the compensating current is not lowered as the voltage drops. They are faster, smaller, cheaper and have a higher control bandwidth than SVCs. As for LVRT, the most relevant feature of the STATCOM will be its inherent capability to increase the transient stability margin by injecting a controllable reactive current independently of the grid voltage [20]. The STATCOM has other ad-on features such as electromagnetic torque control, harmonic control, and high short term overload capacity, which makes it even more attractive. Figure 8, represent the basic STATCOM which can be used in LVRT capability for wind turbines [21].

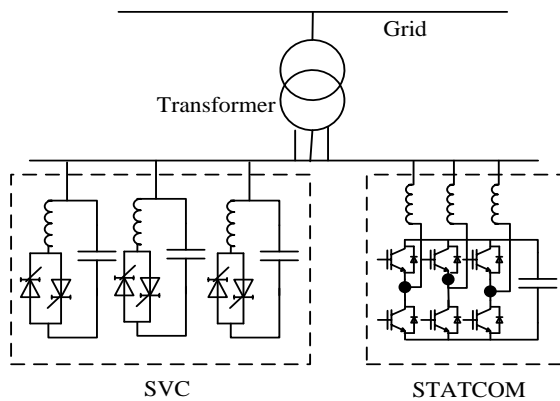

Figure 8: Shunt Compensation using SVC and STATCOM

ii- Series Voltage Compensation:

There are many factors that need to be considered when using series compensators. The most important factors are the large operating range to enable continuous voltage control in recovery period and possibly during the fault as well as the high over-current capability. Utilization of voltage compensation using series converters has been introduced and applied for many applications such as dynamic voltage restorer, static compensators, and harmonic compensations.

Thyristor Controlled Series Capacitor (TCSC)

Being the initial series FACTS controller and has currently the most installations. Thyristor controlled series capacitor (TCSC) was used to increase the power transfer capability. When grid fault occurs, the effective impedance of TCSC can be increased almost immediately by controlling the firing angle α . Therefore, the voltage is compensated and the short circuit current is limited. TCSC has good over-current capability, but suffers from a limited operating range. [22]

Static Synchronous Series Compensator (SSSC)

SSSC consists of a voltage source inverter connected in series through a coupling transformer to a compensated line. The SSSC is used as to create an equal and opposite voltage to the DC link voltage rise experienced during the voltage dip. A source of energy is required for providing and maintaining the DC voltage across the DC capacitor and compensation of SSSC losses. SSSC has a larger operating range than the TCSC, but comes with complex configuration and additional protection arrangements to handle over-currents. [23]

Dynamic Voltage Restorer (DVR):

SSSC version applied in distribution systems is the Dynamic Voltage Regulator (DVR) that basically consists on a three-phase converter connected transformer and with a load element (or source) in the DC side of the converter. A voltage to synchronize it with the line voltage can be injected of a variable amplitude and phase, and this allows the active and reactive power exchange between lines. The energy storage device compensates network voltage sags and improves the unbalances between phases. [24, 25]

Magnetic Energy Recovery Switch (MERS)

MERS has a simpler configuration and potentially low cost over-current protection implementation, as well as the same capacitive operating range as for the SSSC. With new IGBT having low on-state voltage, MERS are becoming more attractive as the initial on state losses are low [26]. In single phase operation, the configuration is similar to a single phase full bridge using four switches but the control differs and the size of the capacitor is several times smaller. [27]

iii- Series and Shunt Compensation:

Unified power flow controller (UPFC) is a back-to-back combination of a shunt converter (STATCOM) and a series converter (SSSC), which are coupled by a common DC-link, to allow bi-directional flow of active power between the series terminals and the shunt terminals of the converters as seen from Figure 9.

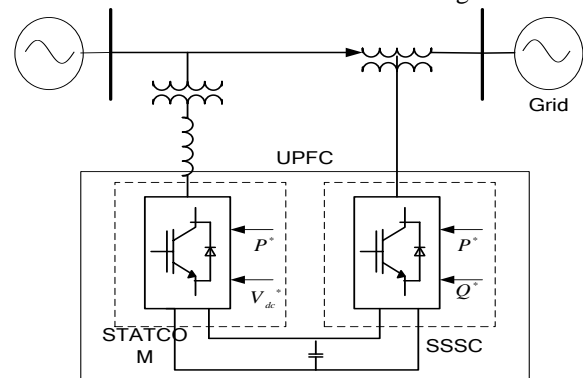

Figure 9: Schematic Diagram for UPFC

UPFC provides concurrent active and reactive series line compensation without an external electric energy source. The series converter injects a voltage which has two orthogonal components when transformed to synchronously rotating reference frame (the direct axis is aligned with phase 'a' of the receiving end). The d-axis component contributes in magnitude variation and quadrature component which contributes in phase angle. The shunt converter functionality can be reactive source compensation (providing inductive or capacitive VAR) or voltage regulation providing reactive power to control the transmission line voltage at a reference value (in condition that the rating of the shunt converter is not exceeded) [28]. Thus, the UPFC can be used to enhance the LVRT capability by means of the state-of-the-art design, construction, control systems, and energy storage facility by means of the DC capacitor.[29]

IV. CONCLUSION

With the large installed capacity of large MW wind turbines, LVRT capability enhancement is becoming one of the most important grid connection issues. This paper demonstrates how network voltage dips affect the LVRT capability of wind turbines by having destructive effects on the power electronic converters and the electrical generator. Several techniques have been outlined to overcome these problems with a brief explanation of each to demonstrate its benefits and drawbacks.

ACKNOWLEDGMENT

Please place an eventual Acknowledgment here, before the References.

REFERENCE

- [1] I. Erlich and U. Bachmann, "Grid code requirements concerning connection and operation of wind turbines in Germany," presented at the IEEE Power Engineering Society General Meeting, 2005., 2005.
- [2] R. Mittal, et al., "Ride through capability of grid interfaced variable speed driven PMSG for wind energy conversion systems," in proceedings of international conference on energy and environment march 19-21, 2009, pp. 406-412.
- [3] M. Tsili and S. Papathanassiou, "A review of grid code technical requirements for wind farms," *IET Renewable Power Generation*, vol. 3, p. 308, 2009.
- [4] G. Joos, "Wind turbine generator low voltage ride through requirements and solutions," presented at the IEEE Power and Energy Society General Meeting - Conversion and Delivery of Electrical Energy in the 21st Century, 2008.
- [5] L. H. Hansen, et al., "Conceptual survey of Generators and Power Electronics for Wind Turbines," Risø National Laboratory, Roskilde, Denmark December 2001.
- [6] A. K. Thet and H. Saitoh, "Pitch control for improving the low-voltage ride-through of wind farm " presented at the Transmission & Distribution Conference & Exposition: Asia and Pacific, 2009 2009.
- [7] *Wind Power in Power Systems*: John Wiley & Sons, 2005.
- [8] Y. Xiao-ping, et al., "Low Voltage Ride-Through of Directly Driven Wind Turbine with Permanent Magnet Synchronous Generator," presented at the Power and Energy Engineering Conference. APPEEC 2009, 2009.[9] J. F. Conroy and R. Watson, "Low-voltage ride-through of a full converter wind turbine with permanent magnet generator," *IET Renewable Power Generation*, vol. 1, p. 182, 2007.
- [10] D. H. Nguyen and M. Negnevitsky, "A Review of Fault Ride Through Strategies for Different Wind Turbine Systems," presented at the Universities Power Engineering Conference (AUPEC), 2010 20th Australasian 2010.
- [11] J. F. Conroy and R. Watson, "Low-voltage ride-through of a full converter wind turbine with permanent magnet generator," *IET Renewable Power Generation*, vol. 1, pp. 182 - 189 2007.
- [12] W. Wang, et al., "Energy Storage based LVRT and Stabilizing Power Control for Direct-Drive Wind Power System," presented at the International Conference on Power System Technology (POWERCON), 2010.
- [13] C. Abbey, et al., "Power Electronic Converter Control Techniques for Improved Low Voltage Ride Through," presented at the Power Electronics Specialists Conference, 2006. PESC '06. 37th IEEE 2006
- [14] G. Ramtharan, et al., "Fault ride through of fully rated converter wind turbines with AC and DC transmission systems," *IET Renewable Power Generation*, vol. 3, p. 426, 2009.
- [15] Y. Xiao-ping, et al., "Low Voltage Ride-Through of Directly Driven Wind Turbine with Permanent Magnet Synchronous Generator," presented at the Power and Energy Engineering Conference, 2009. APPEEC 2009. Asia-Pacific 2009.
- [16] A. Mullane, et al., "Wind-turbine fault ride-through enhancement," *IEEE Transactions On Power Systems*, vol. 20, pp. 1929-1937, NOVEMBER 2005.
- [17] A. C. Lopes, et al., "Reactive Power Control of Direct Drive Synchronous Wind Generators to Enhance the Low Voltage Ride-Through Capability," presented at the iREP Symposium Bulk Power System Dynamics and Control (iREP) - VIII (iREP), 2010 2010.
- [18] F. Deng and Z. Chen, "Low-voltage ride-through of variable speed wind turbines with permanent magnet synchronous generator," presented at the Industrial Electronics, 2009. IECON '09. 35th Annual Conference of IEEE 2009.
- [19] M. Singh, et al., "Grid synchronisation with harmonics and reactive power compensation capability of a permanent magnet synchronous generator-based variable speed wind energy conversion system " *IET Power Electronics*, vol. 4, pp. 122 - 130 2011.
- [20] M. Molinas, et al., "Low Voltage Ride Through of Wind Farms With Cage Generators: STATCOM Versus SVC," *IEEE Transactions On Power Electronics*, vol. 23, pp. 1104-1117, MAY 2008.
- [21] M. H. Ali and B. Wu, "Comparison of stabilization methods for fixed-speed wind generator systems," *IEEE Transactions On Power Delivery*, vol. 25, pp. 323-331, JANUARY 2010.
- [22] E. V. Larsen, et al., "Characteristics and rating considerations of thyristor controlled series compensation " *IEEE Transactions on Power Delivery* vol. 9, pp. 992 - 1000 Apr 1994.
- [23] S. Zhang, et al., "Advanced Control of Series Voltage Compensation to Enhance Wind Turbine Ride-through," *IEEE Transactions On Power Electronics*, p. 1, 2011.
- [24] M. H. Haque, "Compensation of distribution system voltage sag by DVR and D-STATCOM," in *Power Tech Proceedings, 2001 IEEE Porto* 2001.
- [25] C. Wessels, et al., "Fault Ride-Through of a DFIG Wind Turbine Using dynamic voltage resotrer," *IEEE Transactions On Power Electronics*, vol. 26, pp. 807-815, MARCH 2011.
- [26] G. Wenming, et al., "A Survey on Recent Low Voltage Ride-Through Solutions of Large Scale Wind Farm," presented at the Power and Energy Engineering Conference (APPEEC), 2011 Asia-Pacific 2011.
- [27] J. A. Wiik, et al., "A MERS type Series FACTS Controller for Low Voltage Ride Through of Induction Generators in Wind Farms," presented at the 13th European Conference on Power Electronics and Applications, 2009. EPE '09., 2009.
- [28] M. e. A. Kamarposhti, et al., "Comparison of SVC, STATCOM, TCSC, and UPFC Controllers for Static Voltage Stability Evaluated by Continuation Power Flow Method," presented at the IEEE Electrical Power & Energy Conference, 2008.
- [29] S. Raphael and A. Massoud, "Unified power flow controller for low voltage ride through capability of wind-based renewable energy grid-connected systems " presented at the 8th International Multi-Conference on Systems, Signals & Devices 2011.