

Implementation of Automatic Testing System for Microprocessor Using Logic Analyzer

Dr. Mohamed Saad Zagloul, Engineer Mohamed Saleh

Abstract— This paper is about design of inexpensive technique, to develop new methodologies to solve the difficult challenges facing us today in various processor and SOC design environments. In the past few years, some work has been done on exploiting techniques from test to solve problems in verification and vice versa. Adding to that this research is to provide success in providing an ideal environment for cross-examination of test and verification experiences and innovative solutions for testing Microprocessor using logic analyzer. This thesis is about design of inexpensive method for testing environment that simplifies functional testing of Microprocessor and complete circuit tester. This environment consists of the tester hardware and its corresponding software which enables engineers to experience the challenges of testing and debugging without the expense of costly commercial hardware testers. Simple digital circuits can be constructed using breadboards, wires, and DUTs, then tested using switches and LED's. However, advanced Microprocessor are often too complex to be tested, and debugged in this way, due to the large amount of state they may require and the larger number of input and output signals compared with simple projects. So this system in our study can be used to test complex Microprocessor. The system is described as the design and implementation of a compact, small, cheap, low-power and complete circuit tester. Logic analyzer is used in wide scale of testing digital circuits where it can observe the state of the digital circuits. The Logic analyzer consists of two analyzers. The first part is timing analyzer and the second part is state analyzer. Each has specific functions. Logic analyzer is used to detect the fault in 6802 Motorola microprocessor program In this paper, a high level quick checking method, known as Linear Checking Method can be used to qualify the functionality of a Microprocessor. This can also be used to check hard faults in Memory chips.

Index Terms— Automatic testing; Circuit faults; Circuit testing; DH-HEMTs; Integrated circuit modelling; Logic testing; Microprocessors; Registers; Software testing; System testing.

1 INTRODUCTION

THE The purpose of this paper is to discuss the possible test techniques available to help the reader determine which techniques will be most effective for his/her skill level and available technology. [1] Logic analyzer is used in wide scale of testing digital circuits where it can observe the state of the digital circuits. The Logic analyzer consists of two analyzers. The first part is timing analyzer and the second part is state analyzer. Each has specific functions. Logic analyzer is used to detect the fault in 6802 Motorola microprocessor program.

Rapid advances in areas of nanometer electronic technology and design automation tools enabled engineers to design larger and more complex digital circuits. Recently, most electronic systems consisted of one or multiple printed circuit boards, containing multiple ICs each. Advances in IC design methods and technologies allow integrating these complex systems into one single IC. These developments are driving engineers toward new SoC design methodologies. SoC is seen as a major new technology and the future direction trend for the semiconductor industry. Within the next several years, SoC designers will reduce product development cycle time and place the power in the hands of SoC designers. On the other hand, the more complex are getting electronic systems, the more important become problems of test and design for testability. This is because costs of verification and testing are getting the major component of design. Today, design and testing are no longer separate issues.

The emphasis on the quality of shipped products, coupled with the growing complexity of system design, requires testing issues to be considered early in the design process. At present, most VLSI and system designers know little about testing, so that companies frequently hire test experts to advise their designers on test problems, and they even pay a higher salary to the test experts than to their VLSI designers, this reflects the today's university education where everyone learns about design, but only truly dedicated engineers learn about testing. Entering into the SoC era means that test must now become an integral part of the VLSI and the system design. The next generation of engineers involved with VLSI technology should be made aware of the importance of test. They must be specially trained in test technology to enable them to produce high quality defect-free products [2].

2 PROCESS OF CIRCUIT DIAGRAM

The complete process of circuit design, simulation, implementation, test, and debug are hard tasks. Even though design description tools and circuit compilers have kept up with the increasing levels of integration found in current implementation media such as FPGAs and microcontrollers, it has become increasingly difficult to test and debug the complex hardware projects enabled by these modern tools and devices. Digital logic implementation technologies emphasize very high levels of integration in various forms such that custom VLSI chips, microprocessor, microcontrollers, and field programmable logic such as FPLDs and FPGAs. For faulty ship the user can not repair the chip. Hence

the users have only two choices: either to continue using the chip with a particular failing function, knowing that the failing function will not be used in the given application or to replace the whole chip. Highly integrated circuits have many advantages, such as lower power, reduced circuit board area, greater functionality, and lower production cost. However, these circuits require more time and money to be invested into complex development tools. The process of circuit design involves several distinct steps:

1. First, the designer specifies the circuit at the appropriate level of abstraction. A circuit can be specified in many different ways, including high-level hardware description languages, schematics, and behavioral models. Hierarchy in the description is helpful for specifying a design in a top-down fashion. Encapsulating a part of the circuit makes it easy to repeat, much like a subroutine in software makes part of the program easy to invoke iteratively or recursively.
2. Second, modern design tools compile the descriptions into a form suitable either for simulation or hardware implementation. Because less expensive than actual circuit construction, simulation is used to validate and debug a design, and reduces the amount of time needed to debug a hardware implementation.
3. The third step is to implement a circuit prototype that can be tested and debugged.
4. The final step is building real hardware to ensure the fundamental concepts which meets the required specification.

In recent years, modern circuit design tools have been introduced to engineers in digital design. The availability of these tools has greatly increased the complexity of projects that engineers are able to undertake. Unfortunately, the tools available for testing and debugging have lagged behind the tools for specification, compilation, simulation, and implementation.

Simple digital circuits can be constructed using breadboards, wires, and simple ICs, and then perform the test using switches and LEDs. However, advanced digital circuits using FPLDs and FPGAs are often too complex to be tested and debugged in this way due to the large amount of state they may require and the larger number of input and output signals compared with simple digital circuits [3]. The increasing complexity of VLSI circuits and transition to SoC or even NoC model have made test generation one of the most complicated and time consuming problems in the domain of digital design. Commercial CAD systems for VLSI design and test are both costly and do not provide a good variety of competing or complementary approaches to a given particular problem. It is good for a designer but not for a researcher whose main goal is the search for new efficient solutions. During the last decade, many different low-cost tools running on PCs have been developed to fill this gap. They usually include the major basic tools needed for IC design such that schematics capture, layout editors, simulators, and place and route tool [4]. An inexpensive digital circuit tester simplifying the test and debug experience is introduced in our study. This environment, consisting of the tester hardware and its corresponding software, en-

ables to experience the challenges of testing and debugging without the expense of costly commercial hardware testers.

3 MICROPROCESSOR CIRCUIT

For our work implementation the MC6802 microprocessor is connected with EEPROM memory by connecting the address and data bus as shown in figure 1

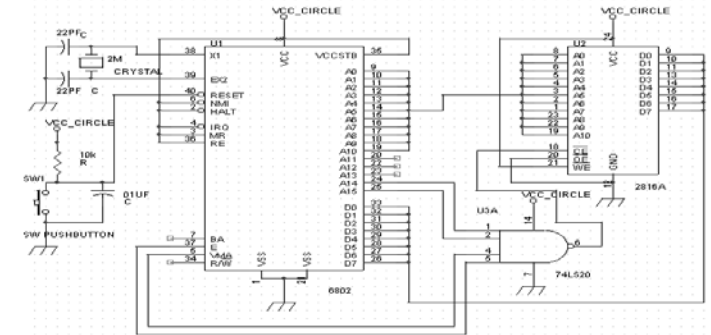

Fig. 1 Schematic of microprocessor circuit 6802 Motorola

Most of wiring connecting the 8 data pins and 11 address pins of the memory to the corresponding pins of the processor.

Two NAND gate inputs at each device (A14 and A15) could select 2^2 or 4 different devices. If A0 through A10 are used for address selection and A14 through A15 are used for chip selection, the three lines A11-A13 are not used for anything, and they can assume any of 2^3 or 8 different states without affecting the chip or address selection of the EEPROM.

The MC6802 has 128 bytes of internal RAM (read/write memory) which is fully decoded for addresses (0000 to 007F); this RAM is enabled if pin 36 is high and disabled if it is low.

The low 32 bytes of RAM are separately powered from pin 35 (5 V at 8mA) to permit a battery supply to save critical data during power down [6]. The image for the circuit is shown in figure -2

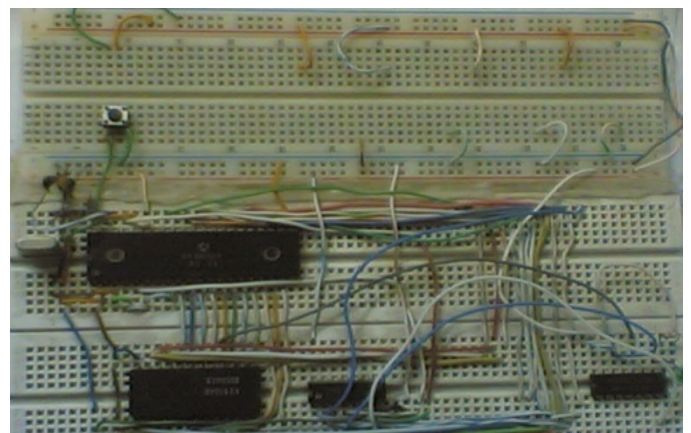

Fig. 2 Image of microprocessor circuit 6802 Motorola

4 THE EEPROM PROGRAMMER CIRCUIT

The EEPROM programmer circuit is used to download the assembly program on the EEPROM 2816A (2 k EEPROM) as shown in figure 5.

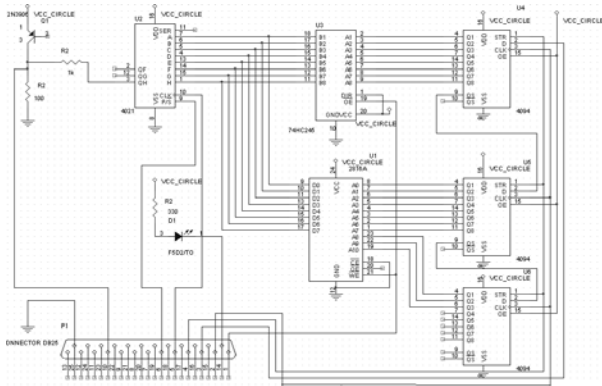

Fig. 3 Schematic diagram of EEPROM programmer

The image of EEPROM programmer is shown in figure 6.

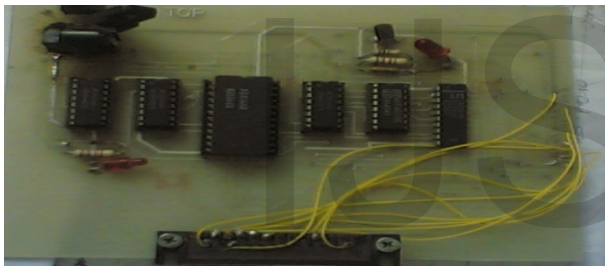

Fig. 4 Image of EEPROM programmer

5 PROGRAMABLE LAMP FLASHER

The 74LS20 NAND gate is used simply as a driver for the LED as shown in figure 7.

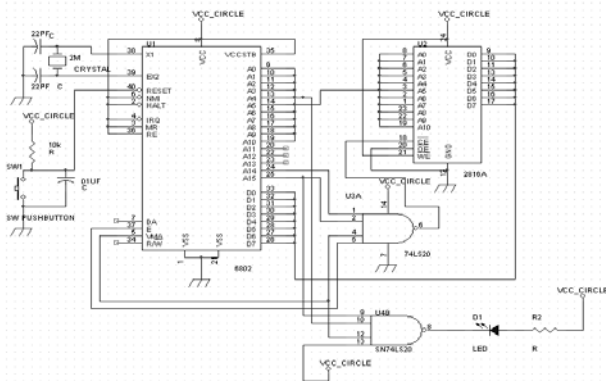

Fig. 5 schematic of programmable lamp flasher

The program of the programmable lamp flasher is given below at table -1.

TABLE 1
 The code of program

Address	OP code	operand	label	mnemonic	operand	cycles
0000	CE	40 00	ON	LDX	#\$4000	
0003	09		LOOP1	DEX		4
0004	27	03		BEQ	OFF	4
0006	7E	00 00		JMP	LOOP1	3
0009	CE	80 00	OFF	LDS	#\$8000	
000C	09		LOOP2	DEX		
000D	27	03		BEQ	GO ON	
000F	7E	00 0C		JMP	LOOP2	
0012	7E	00 00	GO ON	JMP	ON	

It consists of two delay loops, one which keeps address line A4 high, and second which keeps A4 low. The loops count down the X register to produce longer delays than are possible by counting 8-bit RAM location. The length of the ON and OFF times can be changed independently simply by changing the immediate values that are loaded to X before the first and the second loop respectively. The maximum delay is about 1.4 seconds in each loop [6].The bit pattern of the program is shown in table -2

TABLE 2
 Bit pattern of the program

Address	D0	D1	D2	D3	D4	D5	D6	D7	HEX
FFFE	0	0	0	0	0	0	0	0	00
FFFF	0	0	0	0	0	0	0	0	00
0000	0	1	1	1	0	0	1	1	CE
0001	0	0	0	0	0	0	0	1	40
0002	0	0	0	0	0	0	0	0	00
0003	1	0	0	1	0	0	0	0	09
0004	1	1	1	0	0	1	0	0	27
0005	1	1	0	0	0	0	0	0	03
0006	1	1	1	1	1	1	0	0	7E
0007	1	1	1	1	1	1	1	1	FF
0008	0	1	0	1	1	0	1	1	DA
0009	0	1	1	1	0	0	1	1	CE
000A	0	0	0	0	0	0	0	1	80
000B	0	0	0	0	0	0	0	0	00
000C	1	0	0	1	0	0	0	0	09
000D	1	1	1	0	0	1	0	0	27
000E	1	1	0	0	0	0	0	0	03
000F	1	1	1	1	1	1	0	0	7E
0010	1	1	1	1	1	1	1	1	FF
0011	1	1	0	0	0	1	1	1	E3
0012	1	1	1	1	1	1	0	0	7E
0013	1	1	1	1	1	1	1	1	FF
0014	1	1	1	0	1	0	1	1	D7

6 THE RESULT OF TIMING ANALYZER

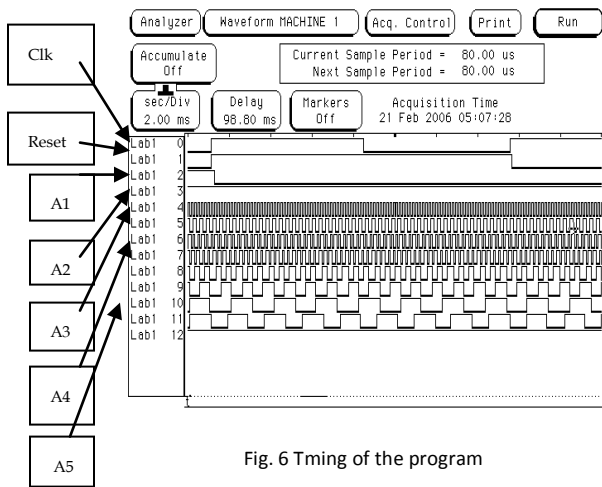

Fig. 6 Tming of the program

7 THE RESULT OF STAT ANALYZER OF VALID MICROPROCESSOR

MACHINE 1 - State Listing

Label	> CLK1	RST2	ADDRESS	DATA
Base	> Hex	Hex	Hex	Hex
0	1	1	FFFE	00
1	1	1	FFFE	00
2	1	1	FFFE	00
3	1	1	FFFE	00
4	1	1	FFFF	00
5	1	1	FFFF	00
6	1	1	FFFF	00
7	1	1	FFFF	00
8	1	1	0000	CE
9	1	1	0000	CE
10	1	1	0000	CE
11	1	1	0000	CE
12	1	1	0001	40
13	1	1	0001	40
14	1	1	0001	40
15	1	1	0001	40
16	1	1	0002	00
17	1	1	0002	00
18	1	1	0002	00
19	1	1	0002	00
20	1	1	0003	09
21	1	1	0003	09
22	1	1	0003	09
23	1	1	0003	09
24	1	1	0004	27
25	1	1	0004	27
26	1	1	0004	27
27	1	1	0004	27
28	1	1	0005	03
29	1	1	0005	03
30	1	1	0005	03

31	1	1	0005	03
32	1	1	0006	7E
33	1	1	0006	7E
34	1	1	0006	7E
35	1	1	0006	7E
36	1	1	0007	FF
37	1	1	0007	FF
38	1	1	0007	FF
39	1	1	0007	FF
40	1	1	0008	DA
41	1	1	0008	DA
42	1	1	0008	DA
43	1	1	0008	DA
44	1	1	0009	CE
45	1	1	0009	CE
46	1	1	0009	CE
47	1	1	0009	CE
48	1	1	000A	80
49	1	1	000A	80
50	1	1	000A	80
51	1	1	000A	80
52	1	1	000B	00
53	1	1	000B	00
54	1	1	000B	00
55	1	1	000B	00
56	1	1	000C	09
57	1	1	000C	09
58	1	1	000C	09
59	1	1	000C	09
60	1	1	000D	27
61	1	1	000D	27
62	1	1	000D	27
63	1	1	000D	27
64	1	1	000E	03
65	1	1	000E	03
66	1	1	000E	03
67	1	1	000E	03
68	1	1	000F	7E
69	1	1	000F	7E
70	1	1	000F	7E
71	1	1	000F	7E
72	1	1	0010	FF
73	1	1	0010	FF
74	1	1	0010	FF
75	1	1	0010	FF
76	1	1	0011	E3
77	1	1	0011	E3
78	1	1	0011	E3
79	1	1	0011	E3
80	1	1	0012	7E
81	1	1	0012	7E
82	1	1	0012	7E
83	1	1	0012	7E
84	1	1	0013	FF
85	1	1	0013	FF
86	1	1	0013	FF
87	1	1	0013	FF

88	1	1	0014	D7
89	1	1	0014	D7
90	1	1	0014	D7
91	1	1	0014	D7

8 THE RESULT OF STAT ANALYZER OF FAULTY MICROPROCESSOR

MACHINE 1 - State Listing

Label > CLK1 RST2 ADDRESS DATA

Base	> Hex	Hex	Hex	Hex
0	1	1	FFFE	00
1	1	1	FFFE	00
2	1	1	FFFE	00
3	1	1	FFFE	00
4	1	1	FFFF	00
5	1	1	FFFF	00
6	1	1	FFFF	00
7	1	1	FFFF	00
8	1	1	0000	CE
9	1	1	0000	CE
10	1	1	0000	CE
11	1	1	0000	CE
12	1	1	0001	40
13	1	1	0001	40
14	1	1	0001	40
15	1	1	0001	40
16	1	1	0002	00
17	1	1	0002	00
18	1	1	0002	00
19	1	1	0002	00
20	1	1	0003	09
21	1	1	0003	09
22	1	1	0003	09
23	1	1	0003	09
24	1	1	0004	27
25	1	1	0004	27
26	1	1	0004	27
27	1	1	0004	27
28	1	1	0005	03
29	1	1	0005	03
30	1	1	0005	03
31	1	1	0005	03
32	1	1	0006	7E
33	1	1	0006	7E
34	1	1	0006	7E
35	1	1	0006	7E
36	1	1	0007	FF
37	1	1	0007	FF
38	1	1	0007	FF
39	1	1	0007	FF
40	1	1	0008	E3
41	1	1	0008	E3
42	1	1	0008	E3
43	1	1	0008	E3

Fault location

This fault causes the program to start light the led and then go to OFF all the time.

Other example of microcontroller and its board in figure 3 is embedded design for a single board computer SBC8600B which has an expansion board to carry the Mini8600B. The flexible design allows the fast and easy way of realizing and upgrading the controller's capabilities. In addition to those features offered by Mini8600B, the SBC8600B features 5 serial ports (including (2) RS232 and (3) TTL), 2 USB Host and 1 USB OTG, 2 Ethernet ports, CAN, RS485, LCD, Touch screen, Audio, ADC and more other peripherals. The SBC8600B is a ready-to-run platform to support for Linux 3.2.0, Android 2.3 and WinCE 7 operating systems, - 720-MHz TI AM3359 ARM Cortex-A8 microprocessor- On Board 2*256MByte DDR3 SDRAM + 512MByte NAND Flash .all the data shown for Mini8600B Processor are belong Embest reference. [7]

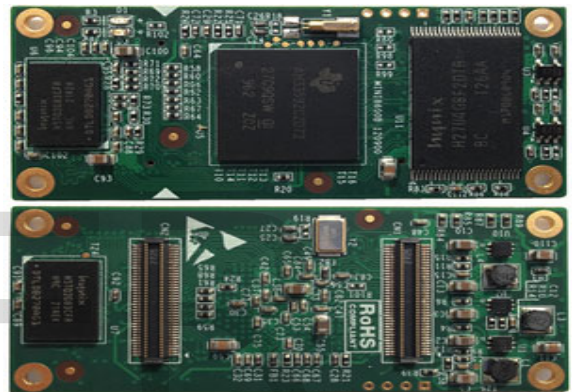

Fig. 7 Mini8600B Processor Card [7]

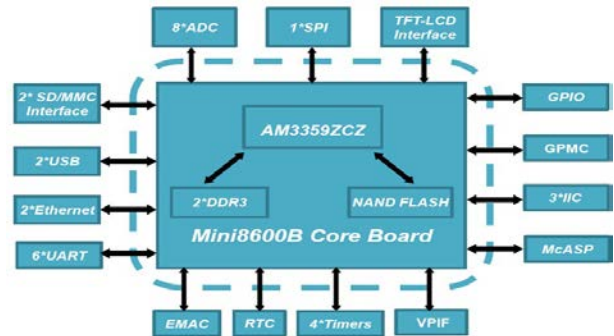

Fig. 8 Mini8600B Function Block Diagram [7]

CONCLUSION

The system is inexpensive yet versatile for testing microcontroller and microprocessors, and subsystems. The component cost is very low comparable to the function which it executes. It is used as a hardware test bench using logic analyzer development environment. It can be used to test variety of projects using highly integrated logic such as microcontrollers and custom chips. [8]

The implementation of the tester increases the circuit density and reduces the cost. Besides making it possible to add features and fix design bugs long after printed-circuit board were fabricated. the system consumes little power and sink only a few milliamperes per pin. The number of wires the engineers must install on the tester's socket is limited to the power and ground connections as the tester maps the remainder of the pins through the microprocessor. This feature improves the setup and reduces the time; as a result, engineers are encouraged to test more often and more completely. Designing straightforward programming interface to the tester is used to simplify the task of integrating it into different user environment. Parallel cable interface to the host makes the system cheaper. The system achieves the high speed of testing and can be used to test more complex designs according the requirements. It can be used in wide scale in commercial as testing system of any digital circuits. Moreover this paper presents a new and systematic method to generate tests for microprocessors. A functional level model for the microprocessor is used and it is represented by a reduced graph. A new and comprehensive model of the instruction execution process is developed. Various types of faults are analyzed and it is shown that with the use of appropriate code words all faults, this gives rise to a systematic procedure to generate tests which is independent of the microprocessor implementation details. Tests are given to detect faults in any microprocessor.

[9]

REFERENCES

[1] Testing Requirements for Microprocessor Relay by Chris Werstiuk, Manta Test Systems 19
<https://www.eiseverywhere.com/.../8fd4ffba80825b3a6fdb06a834f5c67>.

[2] A. Jutman, R. Ubar, V. Hahanov, O. Skvortsova, "Practical Works for On-Line Teaching Design and Test of Digital Circuits," in Proc. of 9th IEEE International Conference on Electronics, Circuits and Systems (ICECS'2002), Dubrovnik, Croatia, Sept. 15-18, 2002, Vol. 3, pp. 1223-1226

[3] MCKENZIE, N. R., EBELING, C., Mc MuReNm, L., ANO BORRIELLO, G. "Experiences with the master in computer science and engineering education". IEEE, Transactions on Education. (February 1997), 12-21.

[4] Aarna, M., Ivask, E., Jutman, A., Orasson, E., Raik, J., Ubar, R., Vislogubov, V., H. D. Wuttke." Turbo Tester - Diagnostic Package for Research and Training". Radio electronics & Informatics, KNURE. Vol. 3(24), 2003, pp. 69-73.

[5]D. Harris, "A Freshman Advising Seminar on Digital Electronics and Chip Design" in Proc. ASEE Annual Conf., 2002.

[6] Charles K Adams , Master handbook of microprocessor chips, Blue Ridge Summit, Pa, 1981.

[7] webmaster Tower B 4/F, Shanshui Building, Nanshan Yungu Innovation Industry Park, Liuxian Ave. No. 1183, Taoyuan St.,

Nanshan District, Shenzhen, China(518055)Tel: +86-0755-25635656-865/866/867/868/863 Fax: +86-0755-25635626-666 www.embest-tech.com www.timll.com www.embedinfo.com

[8] M. S. Zaghoul, M Saleh, Field Programmable Gate Array (FPGA) implementation of the portable automatic testing system for IC'S library and digital circuits, IEEE Applied Imagery Pattern.

[9] Brahme, D.; Abraham, J.A., "Functional Testing of Microprocessors," Computers, IEEE Transactions on, vol.C-33, no.6, pp.475, 485, June 1984doi: 10.1109/TC.1984.1676471

IJSER